

Fully Automatic Bruderer
BSTA 410 Production Line

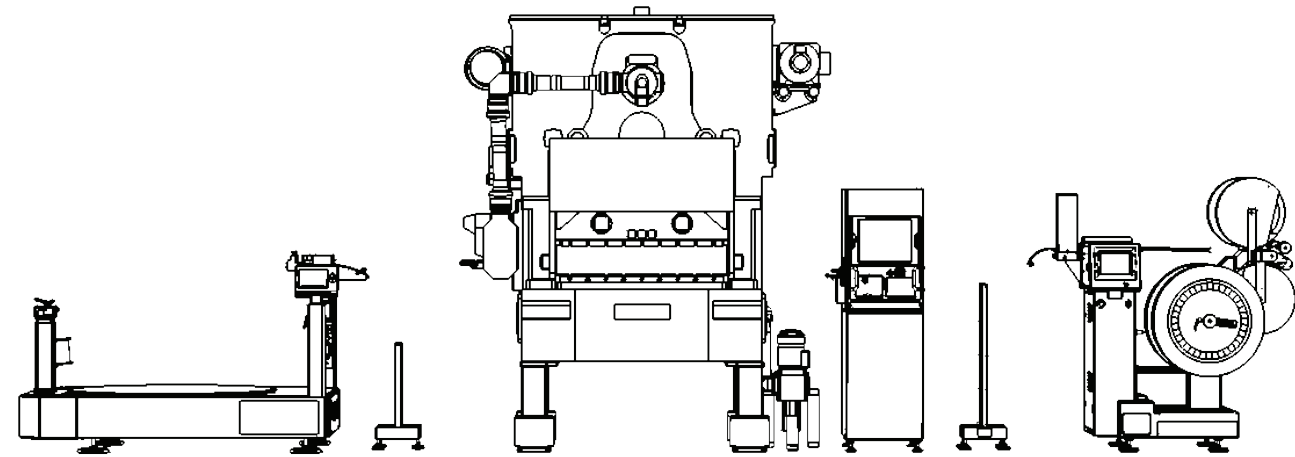

BRUDERER CAN MAXIMIZE EFFICIENCY AND MINIMIZE LABOR COST BY SUPPLYING
TURN-KEY SOLUTIONS WITH STATE OF THE ART SUPPORT EQUIPMENT

HEADQUARTERS
Bruderer Machinery
1200 Hendricks Causeway
Ridgefield, NJ 07657 USA
Telephone: +1 201-941-2121
www.brudereramericas.com
email: info@brudereramericas.com

ALABAMA
4908 Moores Mill Road
Huntsville, AL 35811 USA
Telephone +1 256-519-3658

BRAZIL
R. Guarujá, 702
Zip Code: 06705-425
Cotia -SP, Brazil
Telephone: +55 11 98905-8963



BRUDERER+

PRECISION – SWISS MADE

GENERAL BROCHURE

BRUDERER+

PRECISION – SWISS MADE



**BRUDERER presses range in speeds up to 2500
strokes per minute and capacity up to 250 tons**



10 TON MINI
100-500 SPM



BSTA 180-36
100-1400 SPM



BSTA 200-60/70
100-2500 SPM

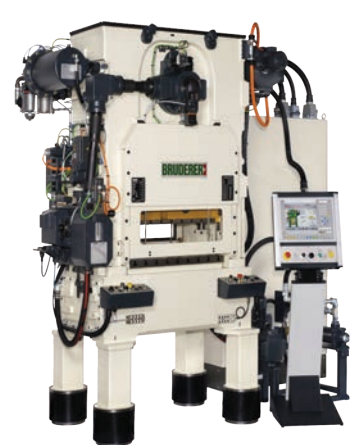

BSTA 280-75/88
100-2000 SPM



BSTA 410-110
100-1600 SPM



BSTA 510-95/110/125/150
100-1120 SPM



BSTA 60 SL
70-700 SPM

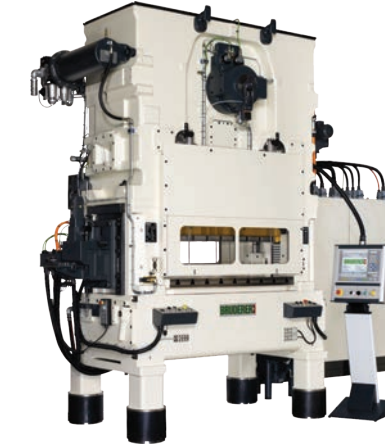

BSTA 810-124/145/180
100-1000 SPM



BSTA 1250-117/151/181
100-850 SPM

We offer a variety of turn-key solutions - our complete line of presses and accessories brings the manufacturing process full circle, offering virtually unlimited possibilities to companies of all sizes.

equipment, lubrication and cleaning solutions, straightening and precision measurement products.

Start with one of our industry leading precision punching presses. Add a complete range of accessories including welders, winding

The result? A comprehensive, high quality manufacturing solution with the ability to grow with your company for decades to come.

VISION SYSTEMS

100% of inspection of geometry, surfaces, and correctness of punched parts. This in-line system incorporates an advanced image-processing algorithm which enables quality inspection with micrometer precision on all stamped parts - even at speeds in excess of 1500 SPM. Zero-Reject Manufacturing.

MATERIAL WELDERS

The RSM / PSM series of automatic welding machines are constructed from precision mechanical components, coupled with state-of-the-art welding control and user-friendly operator panel. This ensures consistent, high-quality welds to significantly improve productivity and tool life.

COIL HANDLING

Coiling innovations from Leicht utilize latest LED loop control technology.

EW-100 series off and re-coilers include the latest innovations from Leicht.

Features include dual sided for quick change, paper interleaf / take up, expansion by crank mechanism, and many more.

PWD-150 Double Pallet De-Coiler offers latest decoiling technology for dual strip production.



EW-100



PWD-150

LUBRICATING AND CLEANING

The industrial production demands clean surfaces. Only then can processes such as lubricating, soldering, gluing, welding and bonding be performed reliably and durably. SLE cleaning systems are water - based, environmentally friendly additions to the stamping line.



MICROLUB BASIC, PREMIUM



SLS S200

SL S500



PSS-40S

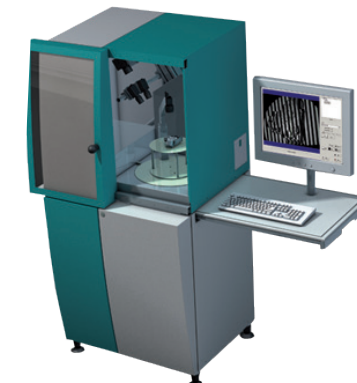

Optical 3D Measurement Technology

VESTER SENSORS

State-of-the-art electronic components for optical sensing, image processing, tool and process monitoring.



SPP x20



RSM 80/90



PSM 050

PRECISION STRAIGHTENERS

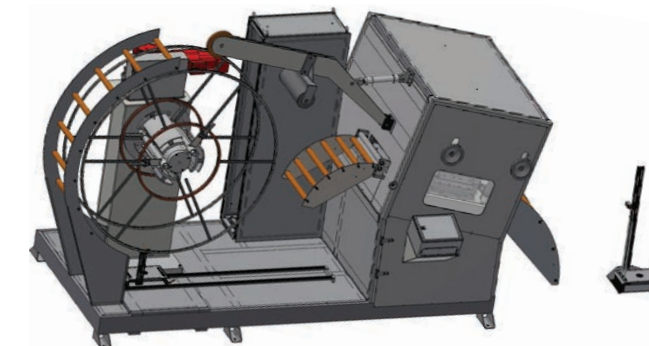

HH 2000



BSTA 1600-117/151/181/220
100-825 SPM

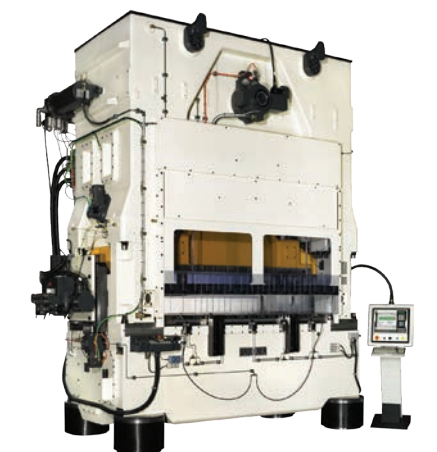

BSTA 2500-270
100-750 SPM